



PRODUCT FEATURES:

iPark light profile is a component for attractive outdoor lighting for garden paths and in entrance areas, on terraces or green areas.

Designed to last in extremely harsh environments.

RECOMMENDATIONS FOR THE USER:

- 1) Before the installation, make sure that there is no voltage.
- 2) Do not touch the fitting when it is working on / switched on
- 3) Do not look at the fitting directly or from a short distance.
- 4) Disconnect / switch off the fitting before changing the lamps

NOTES:

- Technical amendments are reserved.
- CE – Conformity mark
- The manufacturer is then discharged from liability when damage is caused by improper use or installation.
- Clean luminaire regularly with solvent-free cleansers from dirt and deposits. Do not use high pressure cleaners.

1) - The gijons are screwed into the anchor.

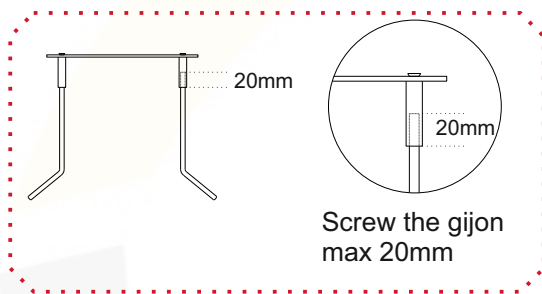
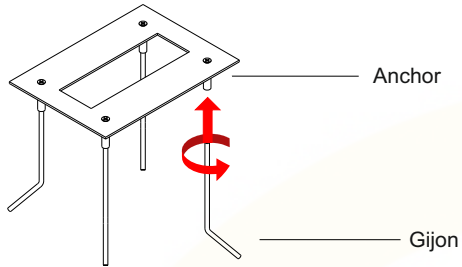

3) - The prepared anchor is embedded in the concrete and leveled.

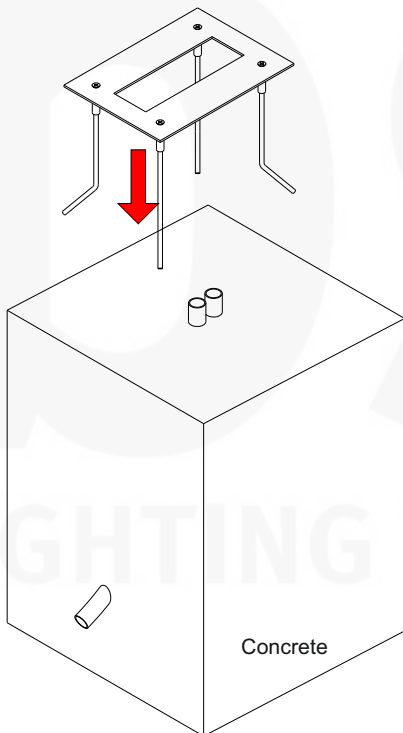

2) The incoming energy hoses are drawn to the installation floor and the concrete is poured

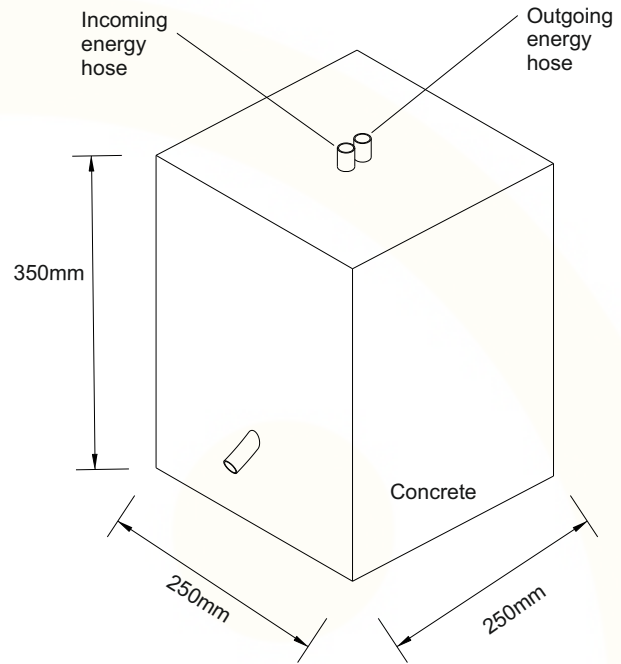

4) After the concrete is dried, the energy cable is done and the temporary screws are removed.

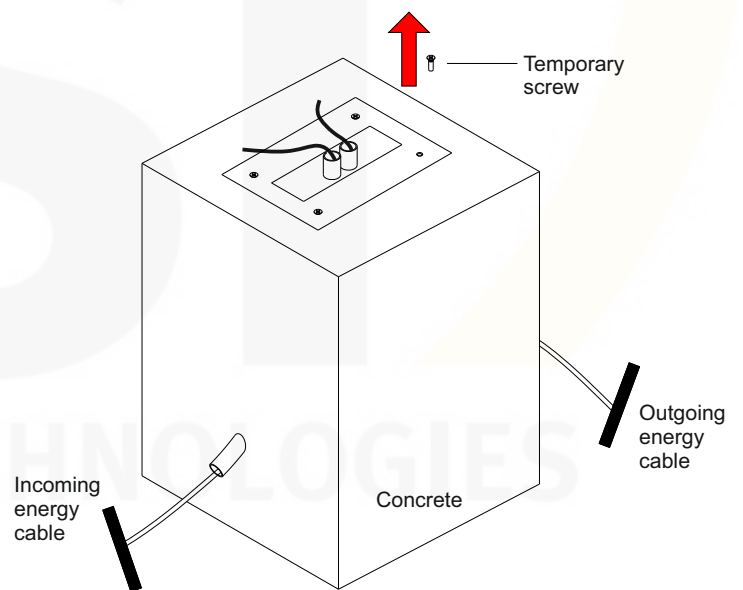

5) Electrical connection is done and luminaire is placed on the anchorage.

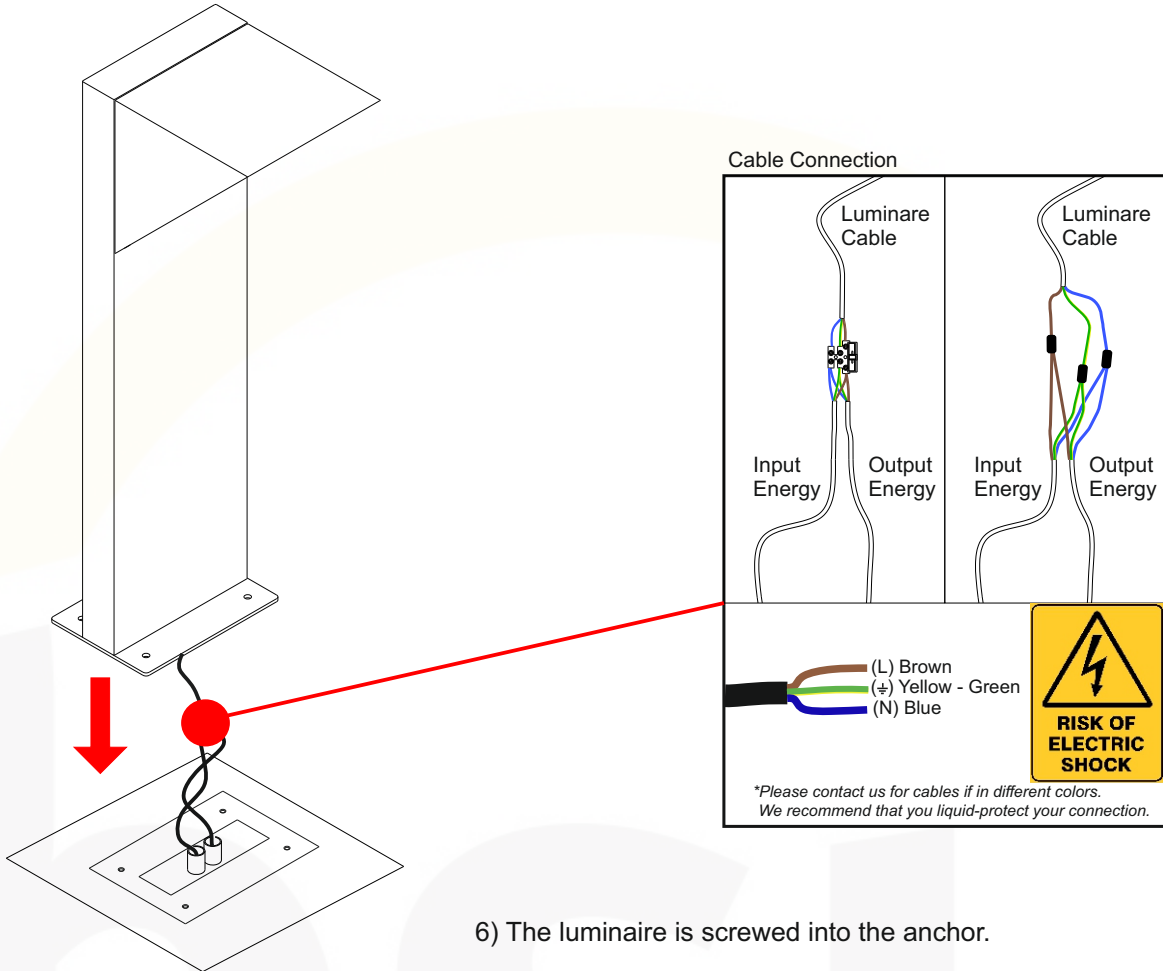

6) The luminaire is screwed into the anchor.

