



PRODUCT FEATURES:

iCone LED bollard with 360° light emission provides simplicity and easy integration into a range of settings.

Designed to last in extremely harsh environments.

RECOMMENDATIONS FOR THE USER:

- 1) Before the installation, make sure that there is no voltage.
- 2) Do not touch the fitting when it is working on / switched on
- 3) Do not look at the fitting directly or from a short distance.
- 4) Disconnect / switch off the fitting before changing the lamps

NOTES:

- Technical amendments are reserved.
- CE – Conformity mark
- The manufacturer is then discharged from liability when damage is caused by improper use or installation.
- Clean luminaire regularly with solvent-free cleansers from dirt and deposits. Do not use high pressure cleaners.

LIGHTING TECHNOLOGIES

1) The anchor bolts are mounted.

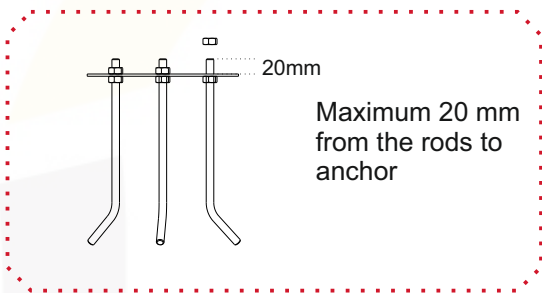
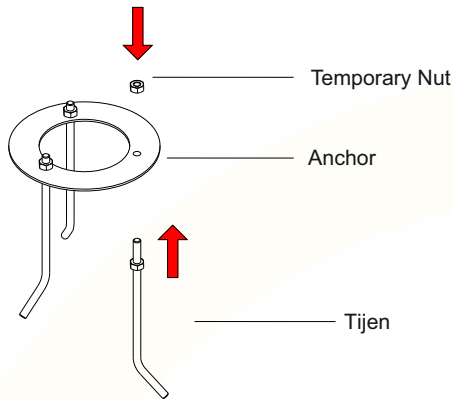

2) The incoming energy hoses are drawn to the installation floor and the concrete is poured

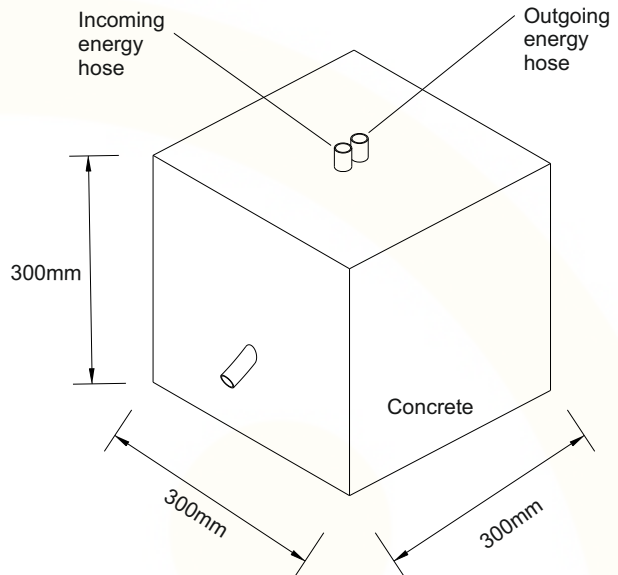

3) - The prepared anchor is embedded in the concrete and leveled.

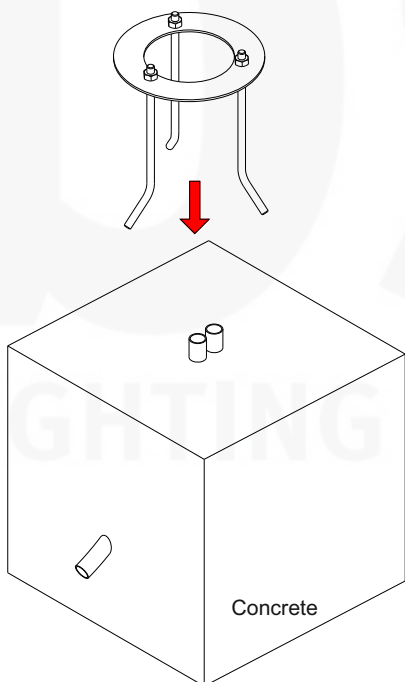

4) After the concrete is dried, the energy cable is done and the temporary nuts removed.

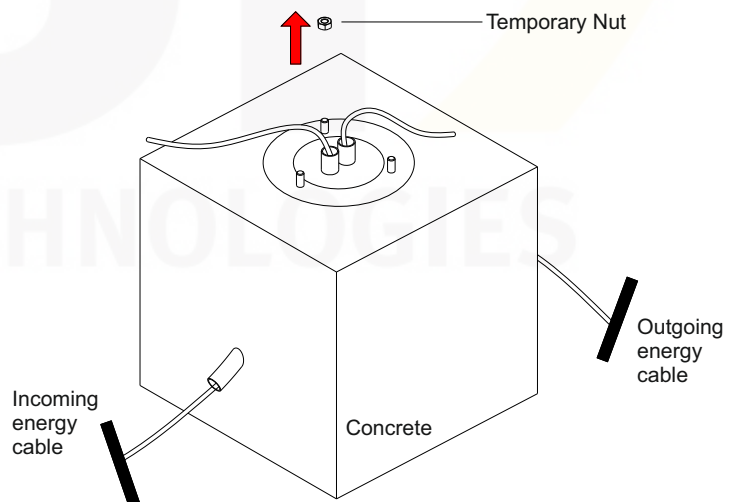

5) The flange is seated on the anchor and the new inox washer is tightened to the threads.

6) Electrical connection is done and luminaire is placed on the flange.

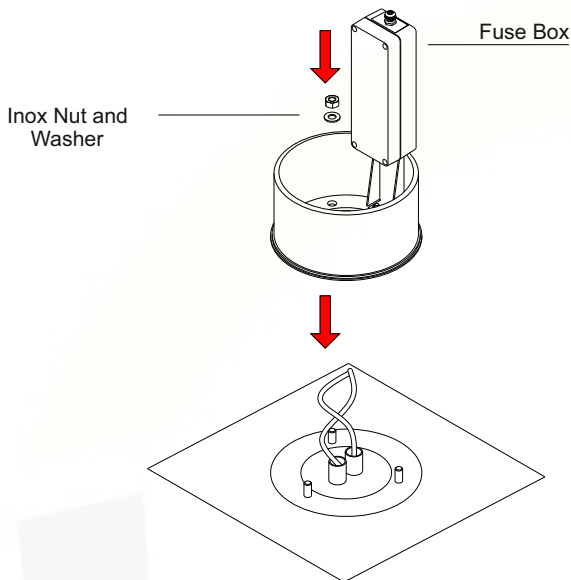

7) Luminaire is fixed to the flange with fastening the setscrews below

